

| | | |
|-------------|-----------|-----------|
| Date : | 09.12.93 | Sign: tmd |
| Last rev: | 06.05.09 | Sign: tb |
| Doc. No: | K4-10/06E | Sign: tb |
| Page 1 of 1 | | |

Expansion joints BSF, BCC

The system described here is based on a sliding bearing. The coefficient of friction is about 0,05.

The knife must be altered.

The solid lines in figure 6.1 shows the new shape of the knife, while the standard shape is shown with dashed lines. Note that the notch must be cut back. δ is half the total expected longitudinal movement of the beam.

The depth of the column unit must be increased.

The increase must be at least the expected longitudinal movement of the beam. The increase in the moment arm for the knife is normally more than compensated by the reduction in the horizontal force. The slot in the front plate of the column unit must be widened in the bottom to the free width inside the column unit, in order to be able to enter the sliding pad and polished steel plate.

Description of the system:

A layer of plastic (high density polyethylene) is placed in the bottom of the column unit. The thickness is normally 5 mm, and the dimensions in both directions should be 4 mm less than the available space inside the column unit. To distribute the load from the knife, a polished carbon or stainless steel plate of thickness 10 to 15 mm is spot welded to the knife.

The length of the polished plate must be calculated in each case, it depends on the actual loads and the compressive strength of the plastic. The length must be at least equal to the length "s" shown in figure 1.

If the length have to be more than "s", the depth of the column unit must be further increased with the difference between the chosen length and "s". The width should be 4 mm less than the free width inside the column unit.

To secure the correct location of the knife within the column unit the following method may be used: In the design the structural engineer has assumed a basic temperature at which the building shall operate. At that temperature the support point shall be centered in the column unit, as shown in figure 6.2. Based on this, the distance "a" can be calculated. Now a table can be made, showing the distance "a" as a function of the temperature at the time of erection. This is vital information for the erection crew.

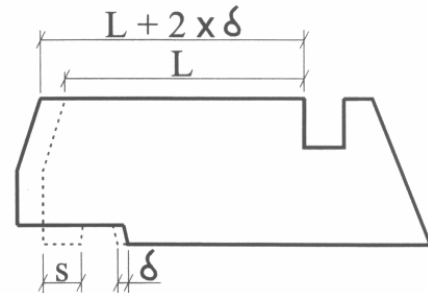

Figure 6.1 Alterations to the knife, the illustration shows a BSF knife

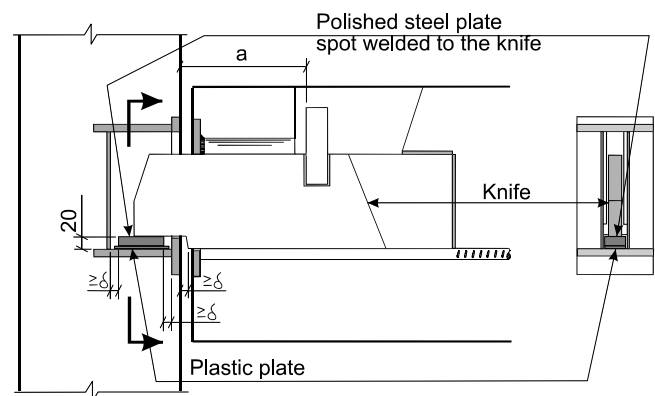

Figure 6.2. Sliding arrangement. The illustration shows a BSF unit